

SPADE ORIENTATION VIEW

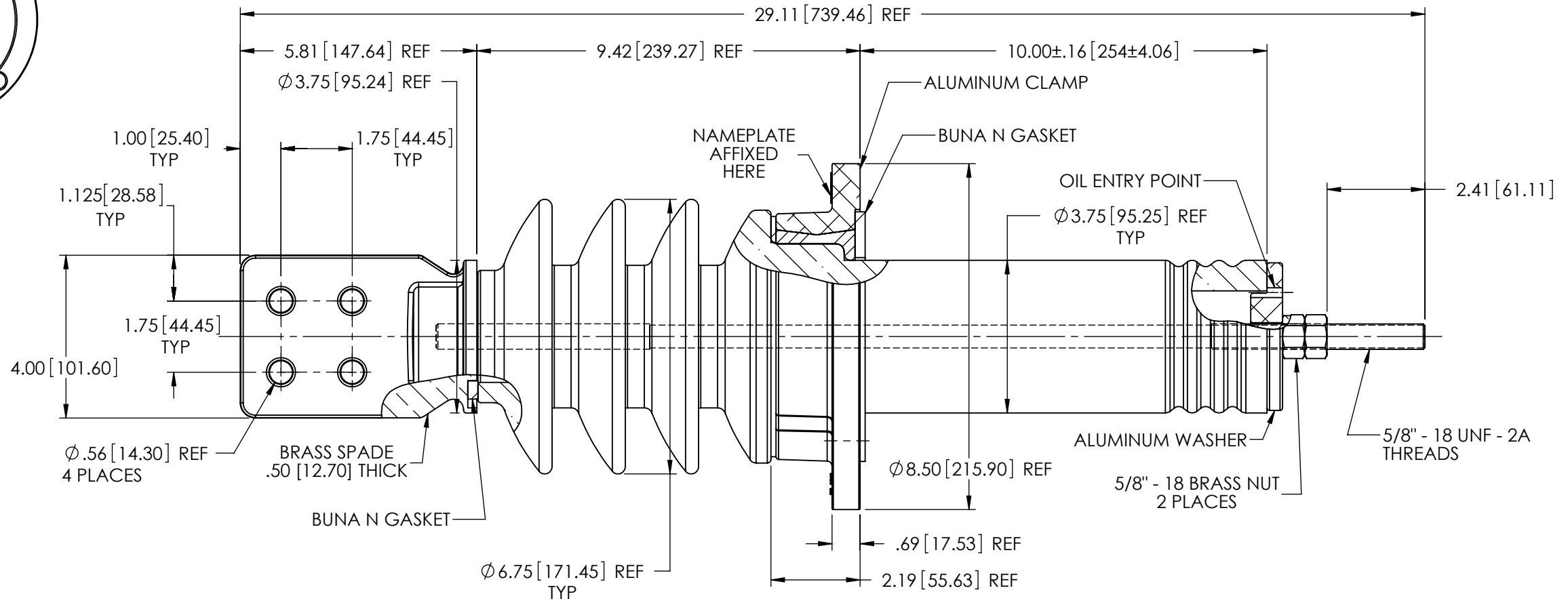

REVISIONS					
REV	DATE	ECN #	DESCRIPTION	BY	APPD
1	8/10/2011	HJ11-122	ADDED NOTES AND SPADE ORIENTATION VIEW	EDS	JFS
2	2/14/2013	HJ13-012	AMP RATING 417 WAS 307.	BS	JFS



- MOUNTING HOLE NOTE:**
1. LOCATED ON A  $\phi 7.25$  [184.15] ON THE ALUMINUM CLAMP.
  2. FOUR(4) THRU HOLES AT  $\phi .688$  [17.46] EQUALLY SPACED  $90^\circ$  APART.

**MATERIAL:**  
 STUD - COPPER C11000  
 SPADE - C84400 TIN PLATED

- NOTES:**
1. SHANK TO FIT INTO  $\phi 4-1/4$ " TANK HOLE.
  2. FOR HORIZONTAL OR VERICAL MOUNTING.
  3. MINIMUM COLD OIL LEVEL - 4" UP SHANK.

- PORCELAIN NOTES:**
1. WET PROCESS ELECTRICAL PORCELAIN.
  2. GRAY GLAZE MUNSELL 5BG 7.0/0.4
  3. TOLERANCE  $\pm 3\%$  WITH NOTHING LESS THAN  $\pm .03$ ", UNLESS OTHERWISE NOTED ON DRAWING.

- SPECIFICATIONS:**
1. VOLTAGE RATING ..... 15KV CLASS
  2. BASIC IMPULSE LEVEL ..... 110KV BIL
  3. NOMINAL CURRENT RATING ..... 417AMPS  $\triangle 2$
  4. CREEP DISTANCE (MINIMUM) ..... 14.40 [365.76]
  5. STRIKE DISTANCE (MINIMUM) ..... 7.67 [194.82]
  6. APPROXIMATE WEIGHT ..... 29.31 LBS

**PROPRIETARY AND CONFIDENTIAL**  
 THE INFORMATION CONTAINED IN THIS DRAWING IS THE SOLE PROPERTY OF H-J ENTERPRISES, INC. ANY REPRODUCTION IN PART OR AS A WHOLE WITHOUT THE WRITTEN PERMISSION OF H-J ENTERPRISES, INC. IS PROHIBITED.

TOLERANCES (EXCEPT AS NOTED)	
DECIMAL	.X" = $\pm .1$ " .XX" = $\pm .06$ " .XXX" = $\pm .03$ "
ANGULAR	+/- 1 Degrees



H - J ENTERPRISES, INC.  
 3010 HIGH RIDGE BLVD. HIGH RIDGE, MO. 63049 USA  
 PHONE 1-636-677-3421 FAX 1-636-376-1915

**15 kV CLASS POWER BUSHING**

MATERIAL	(SEE DRAWING)		
CHK'D	SMM	APP'D	2-14-13
DRAWING NO.	AS1720-001		
DRAWN BY	SMM	DATE	11/18/2010
SCALE	N.T.S.		